

CAD FILE:

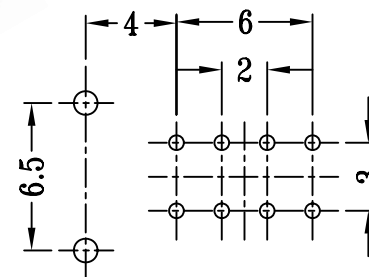
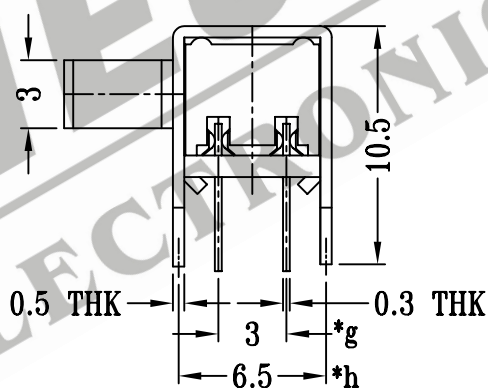
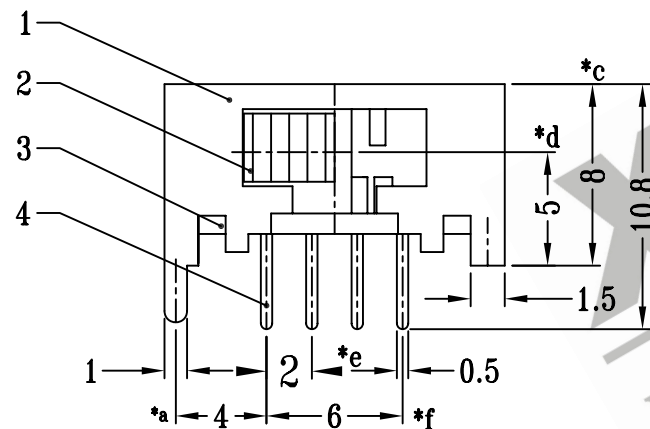
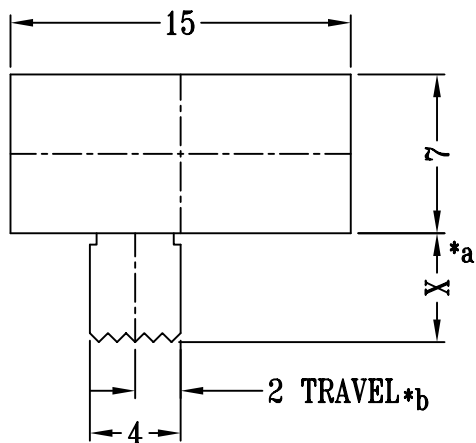

SCHEMATIC (NON-SHORTING)

P.C.B LAYOUT

注:带"*"表示关键尺寸(8个)

NO.	PARTS	MATERIALS	Q'TY	FINISH	TOLERANCE UNLESS SPECIFIED	SHENZHEN XIEJIA ELECTRONICS CO.,LTD.					
8						TITLE : HORIZONTAL SLIDE SWITCH		UNIT : mm	DRWG NO.: XJ-DR-SK23D103-00		
7	STEEL BALL	STEEL	1	NATURAL	WITHIN: 1.5±0.1mm	MODEL: SK-23D103		SCALE: 3:1	DWN.	ZHOUYU	2005-6-5
6	SPRING	STEEL WIRE	1	TEMPER	OVER: 1.5±0.2mm				CHK'D	FANGYING	2005-6-5
5	CONTACT CLIP	PBS	2	Ag CLAD		ISSUE	DATE	DESCRIPTIONS OF REVISION		APPD.	
4	TERMINAL	BRASS STRIP	8	Ag PLATED OVER Ni PLATED					APPD.	KANGXINAN	2005-6-5
3	BASE	PHENOLIC RESIN	1	NATURAL							
2	KNOB	POM	1	BLACK							
1	FRAME	STEEL STRIP	1	Ni PLATED							
					ALL MATERIALS MUST BE COMPLIANT TO ROHS						